



**PARAGON**

**paragon GmbH & Co. KGaA**

**Equity Forum**

Frankfurt | May 13, 2024

“paragon enters the new year with optimism”

“Significant increase in profitability achieved in Q1/2024”

“Forecast for the current financial year confirmed unchanged”





# History of paragon

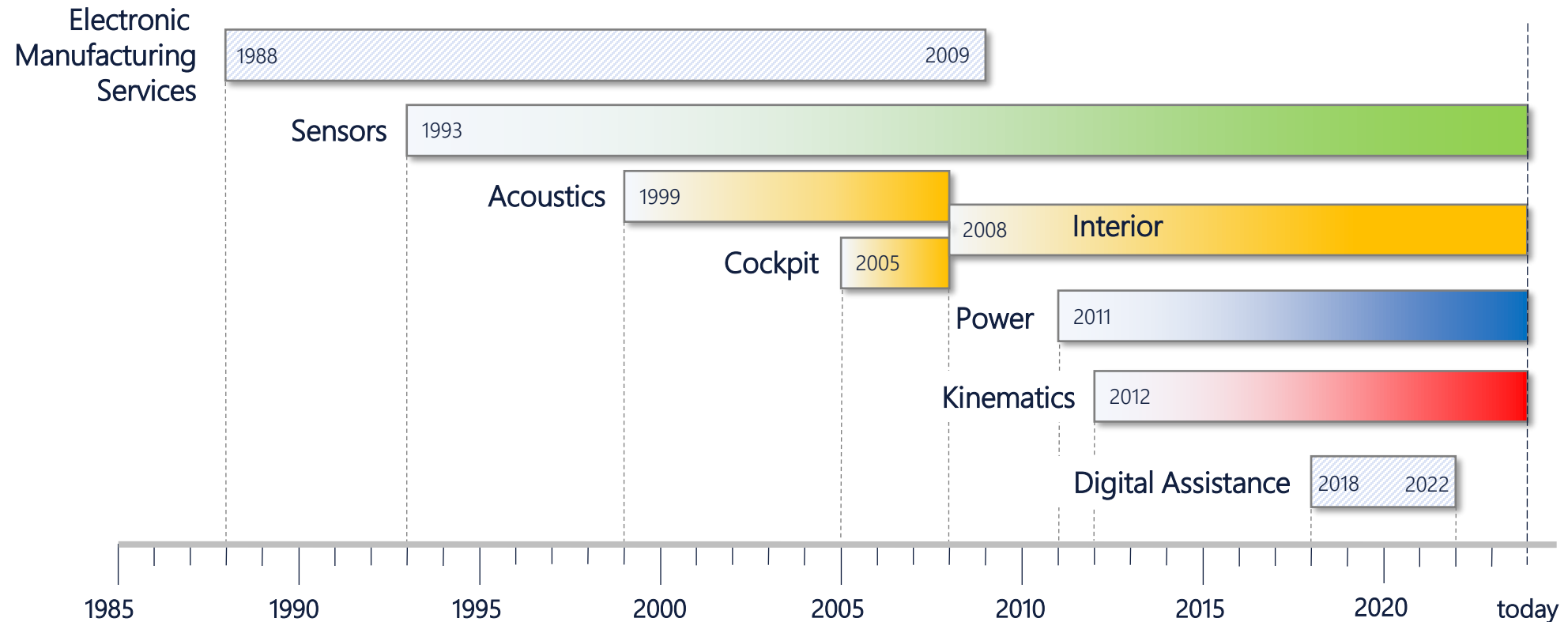

Since more than 35 Years, paragon has build-up an Automotive Tier 1 with Propriety Products

# Global Footprint

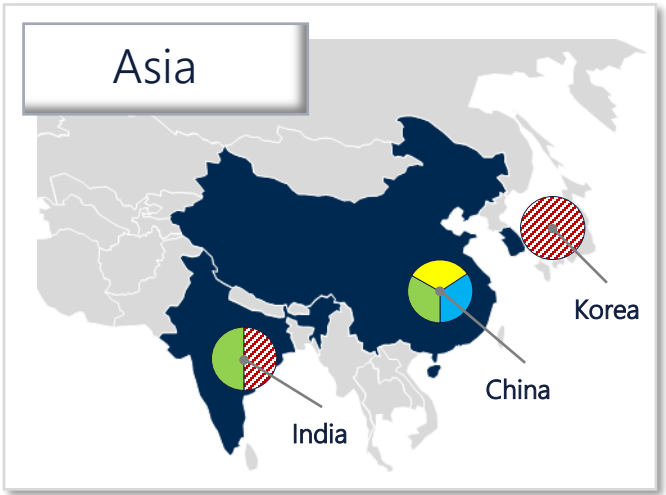
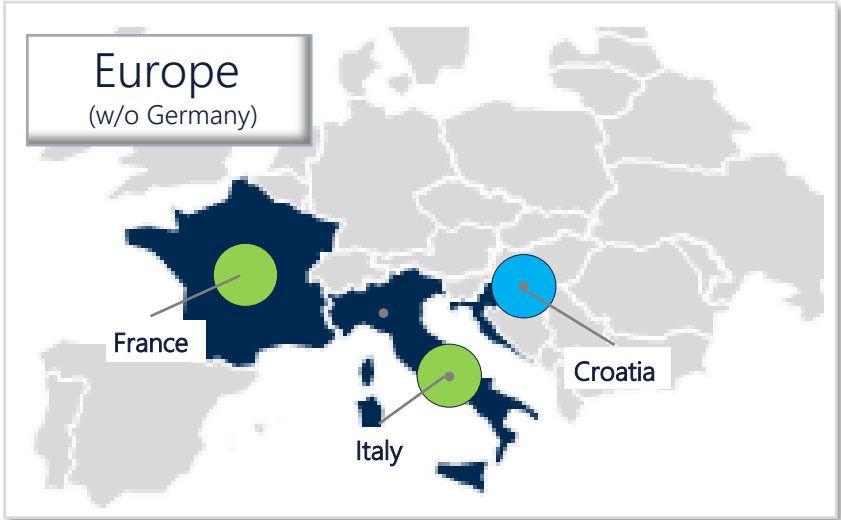
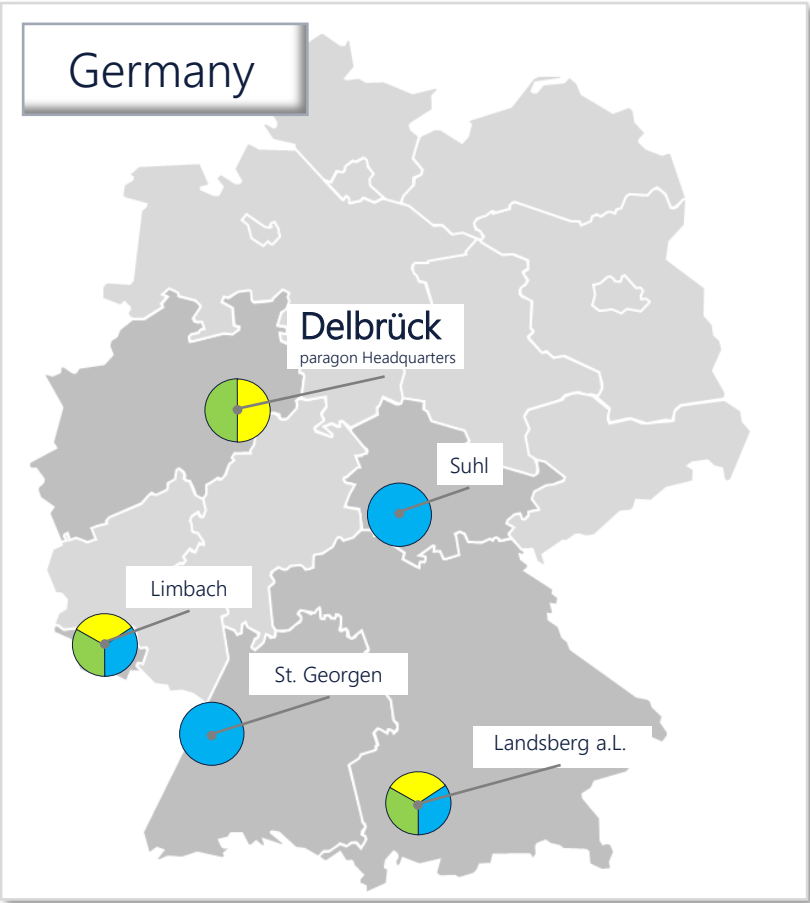

# Product Portfolio Today - Overview

\*) ... of YTD 2023 revenues

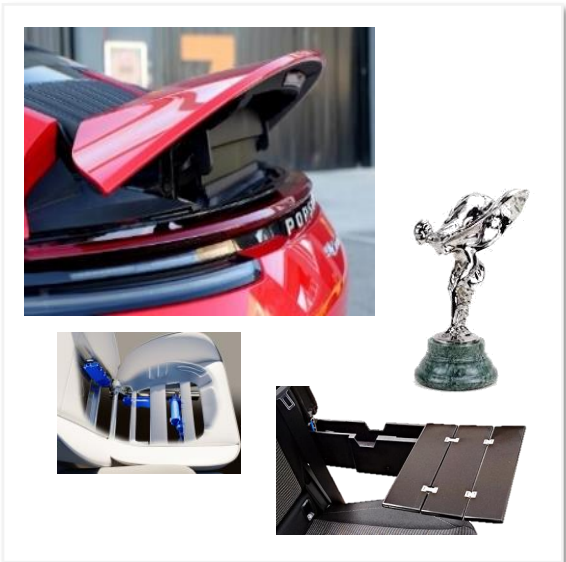
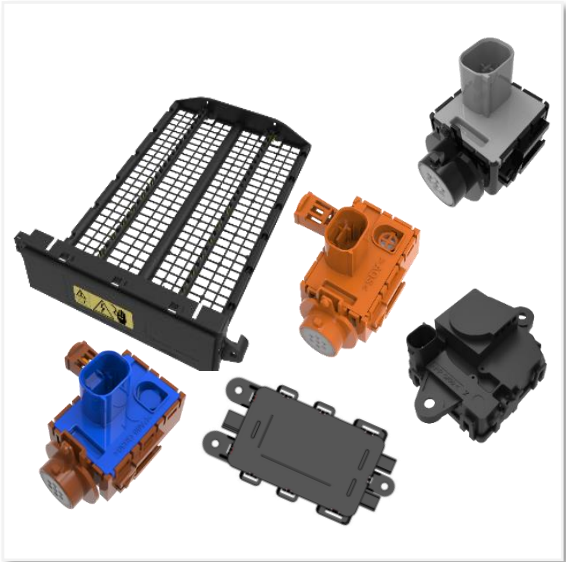

**Sensors** 26% \*)

**Interior** 33% \*)

**Kinematics** 36% \*)

**Power** 5% \*)

**In-Cabin Wellbeing**

**CO<sub>2</sub>-Reduction**

## Product Portfolio Today - Sensors



### Air Quality Sensor

- Automatic control of the vehicle recirculation flap
- Reduction of dangerous emissions inside the cabin
- Advanced technology for detection of toxic gases and unpleasant smell
- High-sophisticated SW-algorithms for detection of special traffic situations
- Over 150 million pcs. produced



### DUSTDETECT

- Measurement of particulate matter outside and in-cabin
- Exterior and interior installation
- Laser sensor with optical particle counting
- Size discrimination PM1, PM2.5 and PM10



### DUSTPROTECT

- High-voltage plasma filter cleans air inside vehicle's cabin by filtering particles and viruses
- Much better than state of the art filtration systems
- Saving space, energy, waste and costs in comparison to HEPA
- Constant efficiency over lifetime

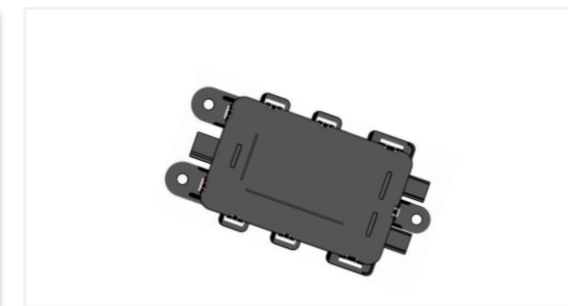

### Air Quality Improver

- Fresh air effect by artificial ionization
- Enhancing of well-being of vehicle passengers
- Fine dusts, gases and smells are bound by negative ions
- Reduction of germs and bacteria in vehicle interior through physical air treatment

**World market leader for In-Cabin Air-Quality**

# Product Portfolio Today - Interior



## Loudspeakers

Broad product spectrum incl. sound systems and signal processing

Tweeters, midranges, woofers, subwoofers, headrest and ultimate speakers

Special solutions like exciters, air motion transformers, high-temperature exhaust speakers, external speakers for e-vehicles

Small to high volumes, entry to award-winning high-end levels

White label branding possible (e.g. B&O, Bespoke Audio, ETON)



## Microphones

Multiple use cases such as voice assistance, vehicle noise control, handsfree and in-car communication, road and wind noise cancellation, external microphones for autonomous driving

Clever combination of acoustical mechanics and adaptive electronic filter

Very low wind sensitivity by active and passive elements

Analogue and digital interfaces

Cutting edge tech and efficient manufacturing



## Instruments

Market leader with very well-known chronometers, analogue clocks, compasses and control applications

The choice for premium and luxury cars

Many more analogue and hybrid instruments for any use case

Own design team to meet any customer requirement

Inhouse stepper motor and plastic parts development and mass production



## Wireless Charging

High efficiency wireless charger based on Qi-standard

Patented active cooling system

Self diagnostic

Member of Wireless Power Consortium (WPC) since 2013

## In-Cabin Wellbeing



# Product Portfolio Today - Kinematics



## Spoilers

Electro-mechanical systems for high variety of vehicles

Application in sportscars, hatch, station cars, SUVs, e-vehicles and trucks

High innovation and realization competence

Range extension for e-vehicle by reduction of air resistance



## Actuators

Drive systems for active spoilers and seat adjustment

Integrated electronics and sensors for advanced vehicle architecture

Multi-stage gear reduction with powerful DC-motors

Fast operation of heavy loads



## Folding Tables

Special folding system to minimize space

Various electronic interfaces (wireless charging, USB-C, displays and keyboards)

Lightweight through use of magnesium and aluminum

Resists head impact

Meets various crash requirements



## Special Kinematics

Tailor-made solutions with cost-effective development

Electrical lowering mechanism of hood ornament

Anti-theft and pedestrian crash protection

Wind deflectors for convertible cars and motorcycles

Easy operation with 3D-movement

## High-sophisticated Kinematics for Exterior and Interior

# Product Portfolio Today - Power



## Battery Management Systems

- Huge background with ECU projects
- Predictive algorithms
- Intelligent balancing
- SW-based safety concept incl. top-edge SOC/SOH-calculation
- New quiescent current concept (deep-sleep and transport modes for extended shelf life)



## Traction Batteries

- Lightweight concepts
- Use of Flow-Shape-Design technology
- Embedded battery safety
- "Lord of the cells" battery management



## Flow-Shape-Design

- Expanded foam as case for battery systems and modules
- Substitution of conventional metal housing
- Less weight/space/costs
- Absorption of shocks/vibration/temperature
- Licenses available

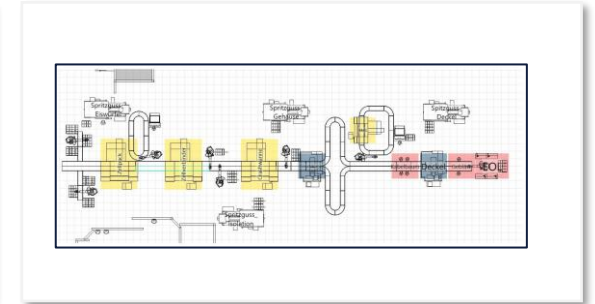

## Consulting

- Technology transfer in regards of Flow-Shape-Design
- Projecting and realization of production lines
- In-house production of test equipment
- Turn-key projects

## Game-Changing Battery Technologies

# paragon's Premium Automotive Customers 2023

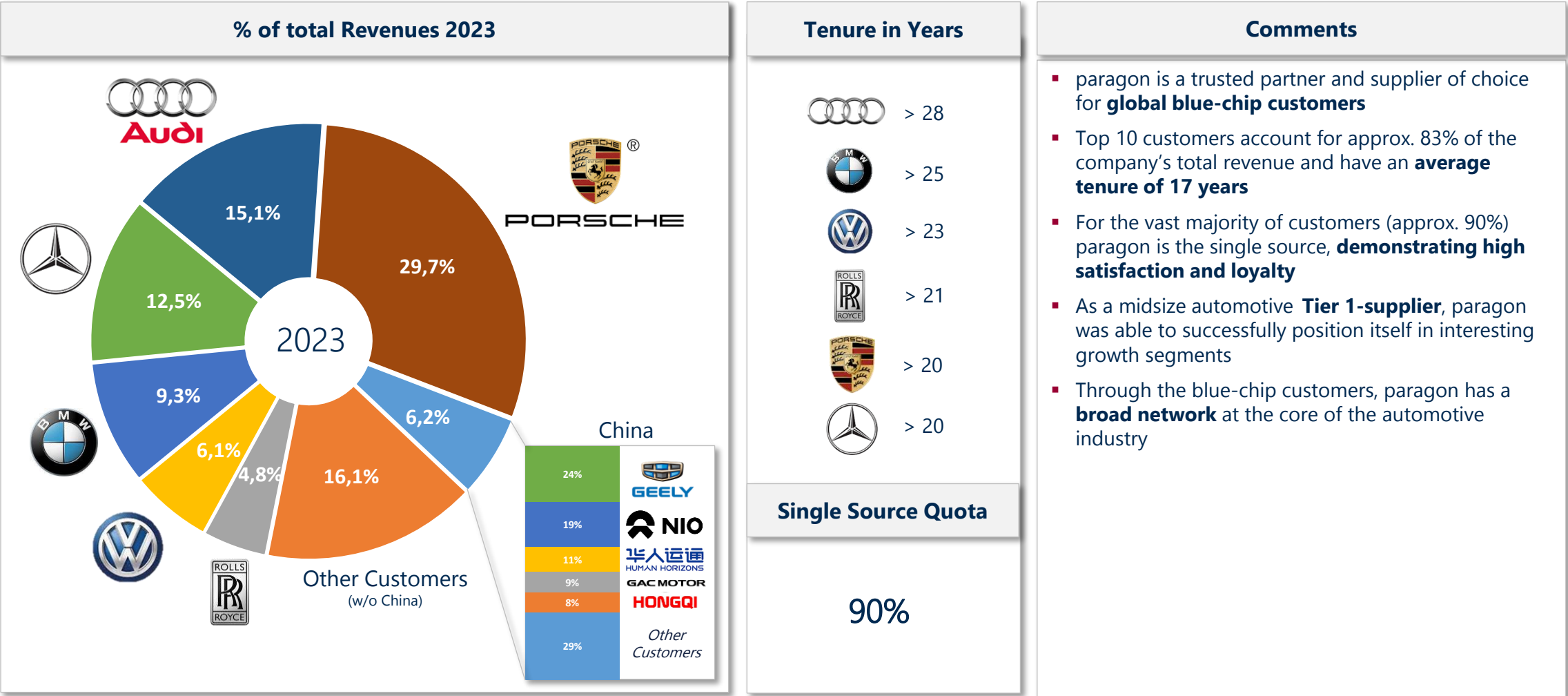

## FY 2023: Financial Highlights at a Glance

Top line stable at EUR 161.6m despite phase out of a sensor product

Asset deal with Clarios lead to a profit in the mid single EURm range

EBITDA (cont. business) at EUR 17.7m; EBITDA (group) at EUR 25.2m

CHF-bond fully repaid; Start of buy-back program for EUR-bond

Reduction of net debt by EUR 30m in one year



# P&L Development paragon

Income Statement in MEUR	2022	2023
Revenues	160,7	161,6
Other own work capitalized	5,1	3,9
Change of finished goods	0,1	-1,5
Other operating income	4,6	12,1
<b>Total operating performance</b>	<b>170,4</b>	<b>176,1</b>
Costs of materials	-94,6	-91,5
Personnel expenses	-41,0	-44,2
Other operating expenses	-24,6	-22,7
<b>EBITDA</b>	<b>10,2</b>	<b>17,7</b>
Depreciation & amortization	-14,6	-16,6
<b>EBIT</b>	<b>-4,4</b>	<b>1,1</b>
EBITDA paragon semvox	4,7	7,6
<b>Group EBITDA</b>	<b>14,9</b>	<b>25,2</b>

## Comments

- ❑ Revenues stable at EUR 161.6m
- ❑ Reduction of own work capitalized due to higher reimbursements of development costs from customers
- ❑ Other operating income includes profit impact of asset deal with Clarios
- ❑ **EBITDA:**
  - Continued operations: EUR 17.7m
  - paragon semvox: EUR 7.6m
  - Group level: EUR 25.2m

# The Financials

## Strong Revenue Growth – Improved Profitability

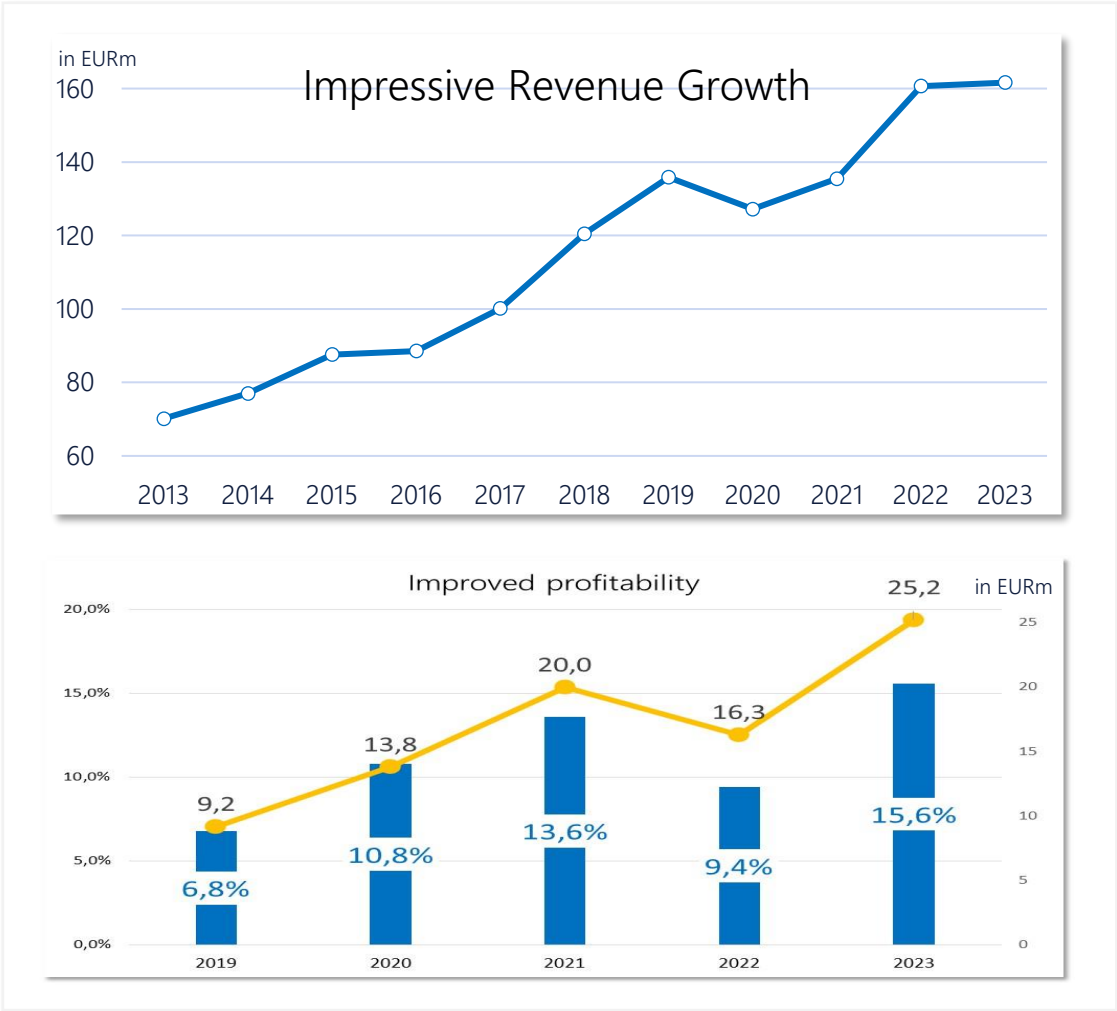

### Comments

#### Revenue Growth

- ▣ paragon increased revenues due to its proven business model by more than 125% in the last ten years (CAGR 8.7%)
- ▣ paragon has demonstrated resilience during past global crises
- ▣ Revenues in 2023 amount to EUR 161.6m although...
  - paragon intentionally ended business with one sensor product by July 2023 (ca. EUR 1.2m/month) and
  - Business with low voltage batteries was sold to Clarios on Sept 30, 2023

#### Improved Profitability

- ▣ EBITDA in 2023 amounts to EUR 25.2m
- ▣ Thereof EUR 7.5m resulting from discontinued operations (prior year EUR 4.7m)

# The Financials

## Substantial Debt Reduction

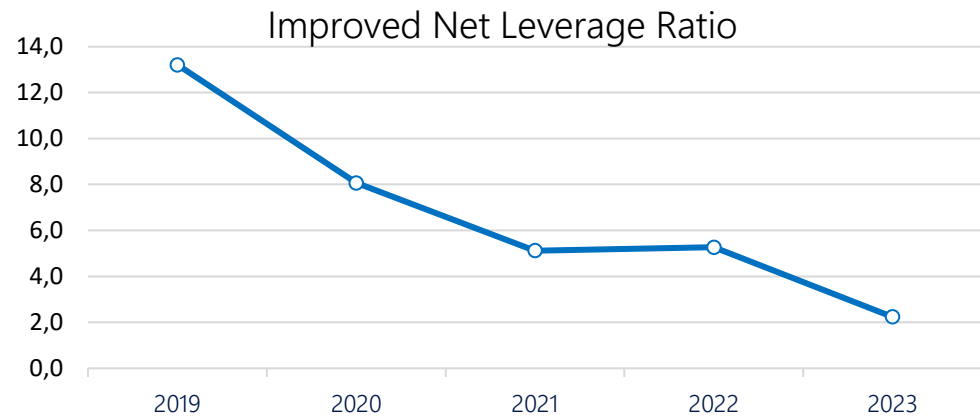
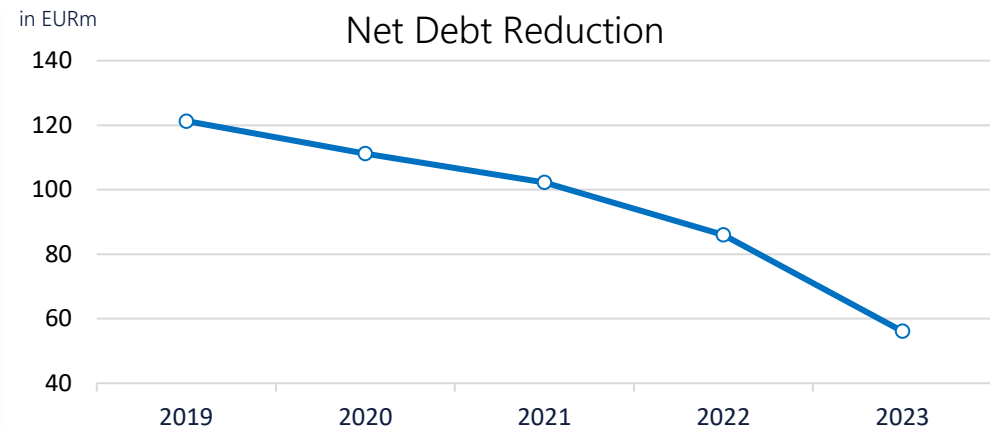

### Comments

#### Net Debt Reduction

- Since end of 2019 net debt was reduced by more than 50% from EUR 121.3m to EUR 57.7m
- Average monthly reduction in the last 48 months was EUR 1.3m
- paragon has achieved a solid base

#### Improved Net Leverage Ratio ("NLR")

- NLR improved from 13.2 to 2.28 in the last four years due to reduced debt level and improved profitability
- Interest rate of bond depends on net leverage ratio; NLR <2.5 led to an interest rate of 7.5% from Jan 5, 2024, on

## News in 2023

### Asset Deal with Clarios

- ❑ Closing on September 30, 2023
- ❑ Agreement includes sale of different production lines and transfer of a group of engineers and workers to Clarios
- ❑ paragon will remain manufacturer of battery management systems for Clarios
- ❑ Clarios licenses paragon's Flow-Shape-Design-Technology (FSD) for non-traction batteries
- ❑ paragon keeps the industrial property rights for FSD in regards of traction batteries



### Director's Dealing

- ❑ September 29, 2023: Klaus Dieter Frers (Managing Director of paragon GmbH) bought back 1,355,000 paragon-shares from ElectricBrands AG for the same price (€ 4.53 per share) ElectricBrands AG acquired the package from him in November 2022 (Total purchase price: € 6,138,150)
- ❑ Klaus Dieter Frers, again, now has 50%+1 total voting rights (before: 20.06%) – now transferred to Frers Family Office GmbH
- ❑ The German Federal Financial Supervisory Authority (BaFin) has exempted him from the obligations to publish a mandatory offer \*)

\*) Pursuant to section 35 (1) sentence 1 WpÜG and pursuant to Section 35 (2) Sentence 1 in conjunction with Section 14 (2) sentence 1 WpÜG and Section 37 (1) Var. 4 of the German Securities Acquisition and Takeover Act (Wertpapiererwerbs- und Übernahmegesetz, WpÜG)



## Corporate Organization ensures Stability

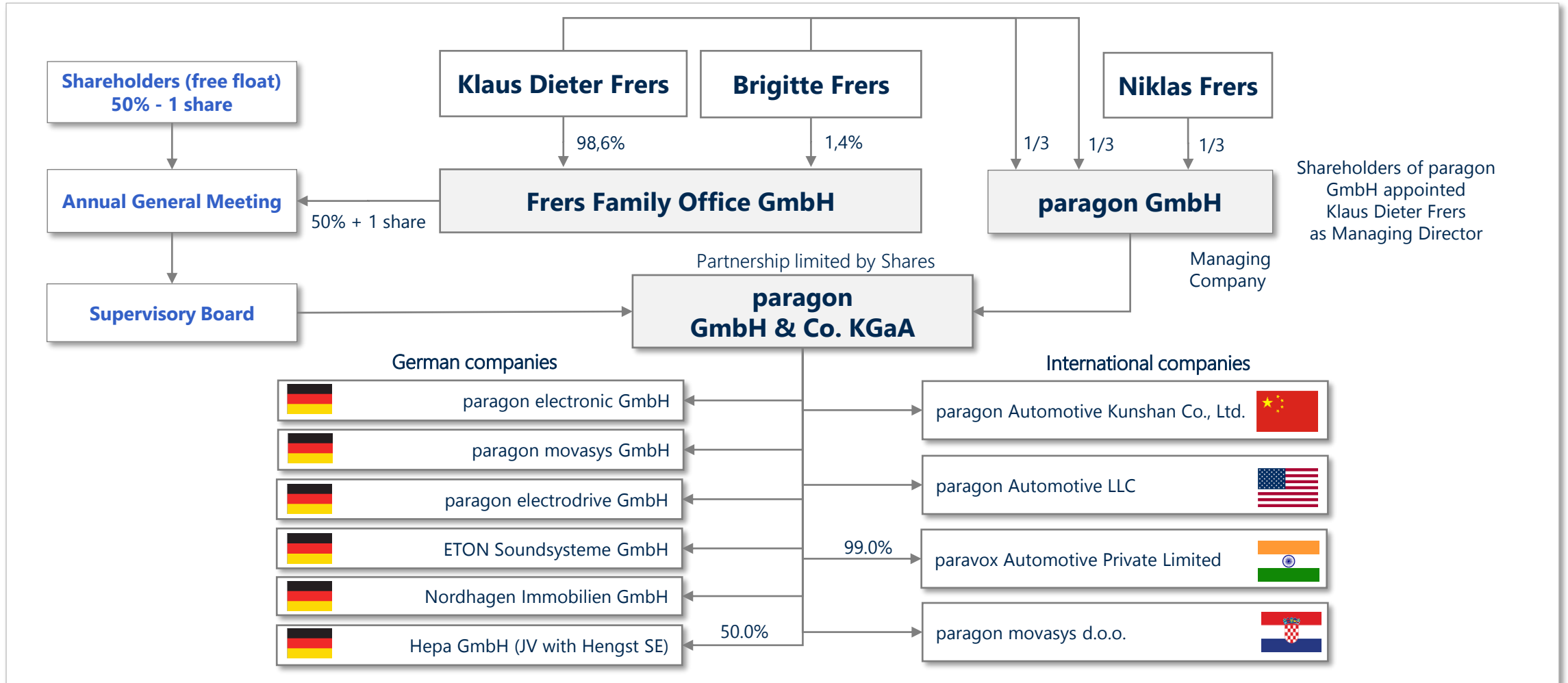

Shareholders of paragon GmbH appointed Klaus Dieter Frers as Managing Director

## Q1/2024: Financial Highlights at a Glance

Revenue in line with expectations

EBITDA at EUR 4.1m or at 10,1%

Improved net debt led to reduced interest expenses

Net loss reduced to EUR 0.5m. Further measures implemented.

Forecast for 2024 confirmed

## P&L Development paragon – First Quarter

<b>Income Statement in MEUR</b>	<b>Q1/2023</b>	<b>Q1/2024</b>
Revenues	44,7	40,9
Other own work capitalized	0,1	0,8
Change of finished goods	-0,8	0,6
Other operating income	1,7	0,6
<b>Total operating performance</b>	<b>45,7</b>	<b>42,9</b>
Costs of materials	-25,4	-23,6
Personnel expenses	-11,1	-10,7
Other operating expenses	-5,4	-4,5
<b>EBITDA</b>	<b>3,8</b>	<b>4,1</b>
Depreciation & amortization	-3,3	-3,2
<b>EBIT</b>	<b>0,5</b>	<b>0,9</b>
Interests	-3,0	-1,6
Taxes	0,2	0,2
<b>Earnings (continued operations)</b>	<b>-2,3</b>	<b>-0,5</b>

<b>Comments</b>	
<input type="checkbox"/>	Revenue and profitability in line with expectation for the first quarter 2024.
<input type="checkbox"/>	Decline in revenue in line with expectation and due to scheduled discontinuation of a sensor product in summer 2023.
<input type="checkbox"/>	Interest costs reduced due to lower net debt level.
<input type="checkbox"/>	Net loss reduced. Further measures being implemented.

## paragon's Substantial Operational Improvement Plan

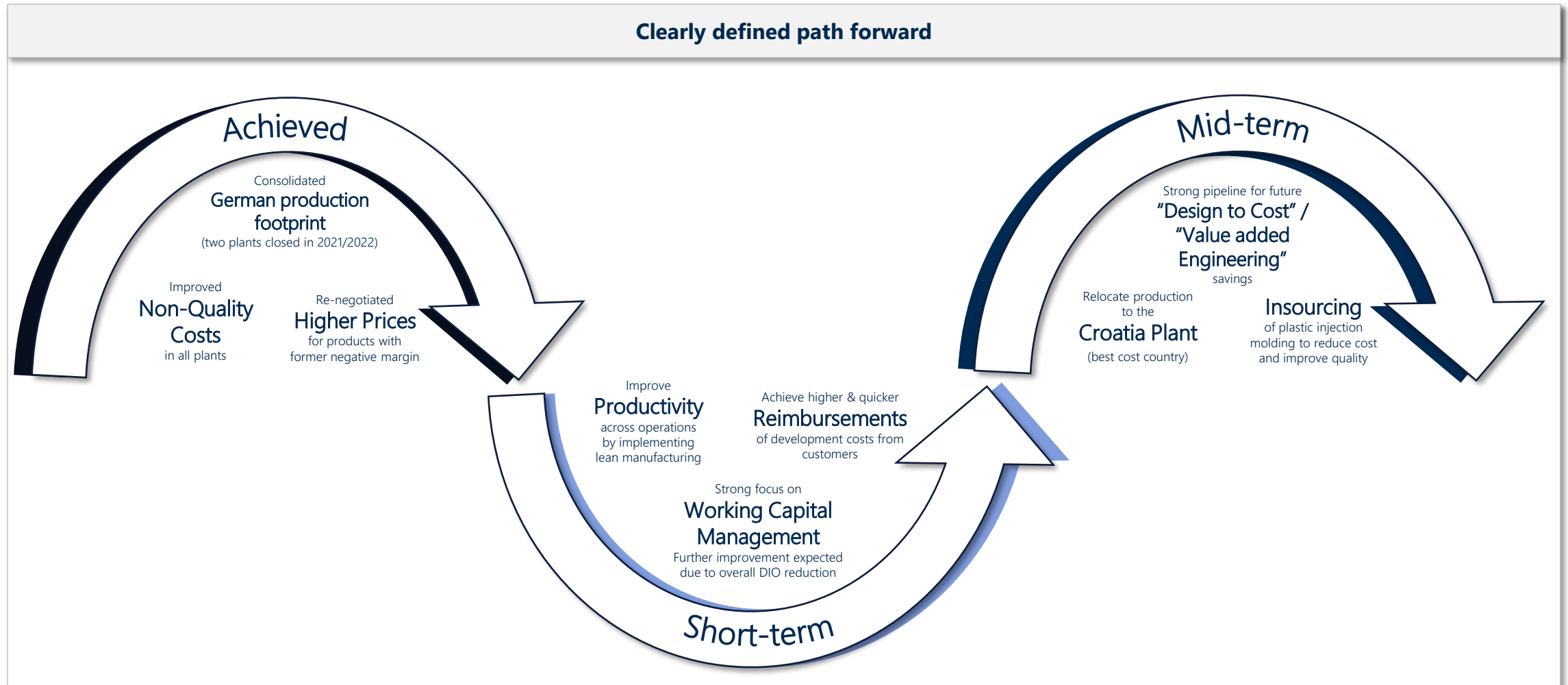



## **Forecast for 2024 (confirmed)**

### **Revenues 2024e**

EUR 160 to 165m

### **EBITDA 2024e**

EUR 18 to 20m

## paragon's Growth Strategy has always Involved

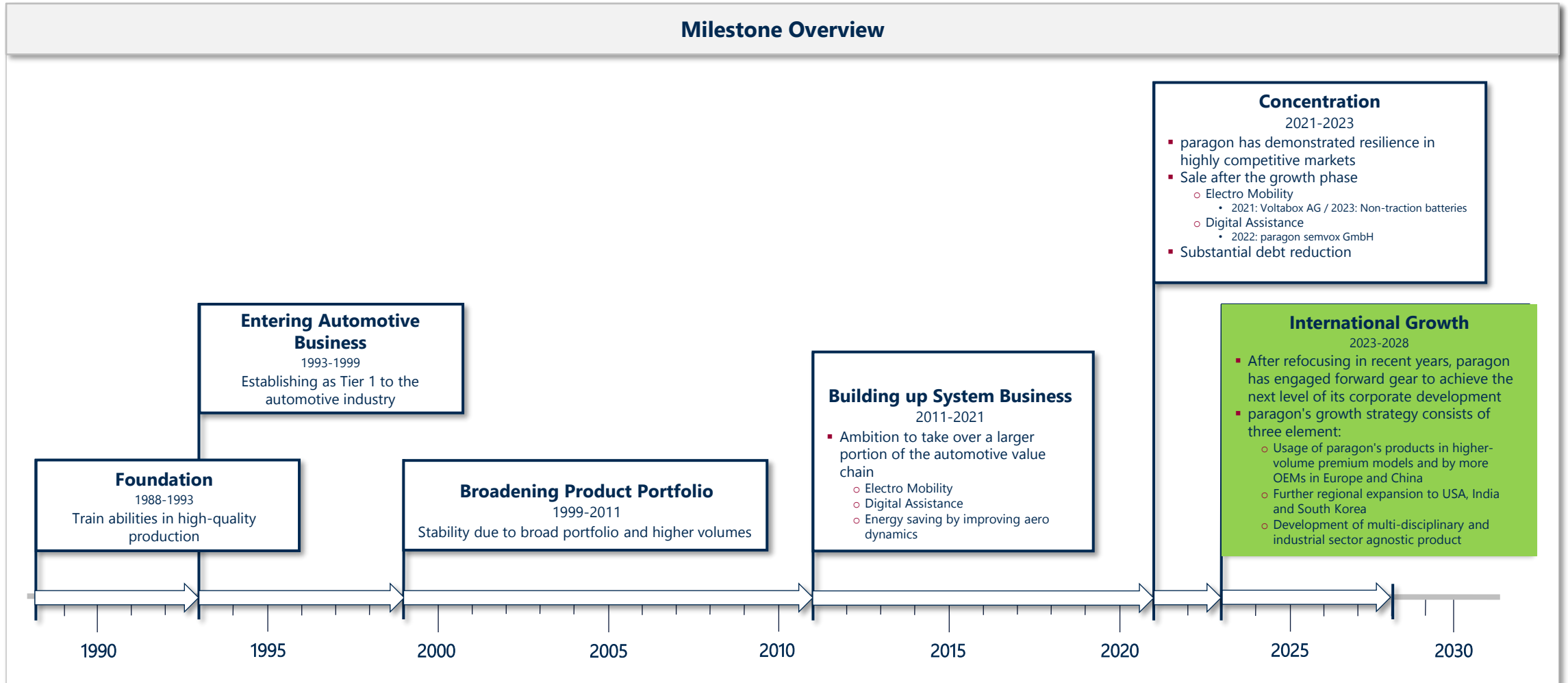

# The Strategy

## Strategy for paragon's ongoing Growth - Intensification of using Growth Drivers

### Sensors

- Full roll-out of electric filter DUSTPROTECT
- eHEPA – using DUSTPROTECT-technology for HEPA-filters to reduce their space needs
- Addressing the upcoming fuel-cell market with sensors for SO<sub>2</sub> (sulfur dioxide) and filter lifetime
- Next level of enhancing in-cabin air quality (sterilization / neutralization of odors)
- Infrared CO<sub>2</sub> and propane sensor for climate systems (actual cooling medium will be banned)

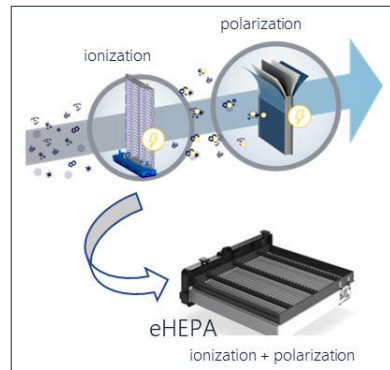
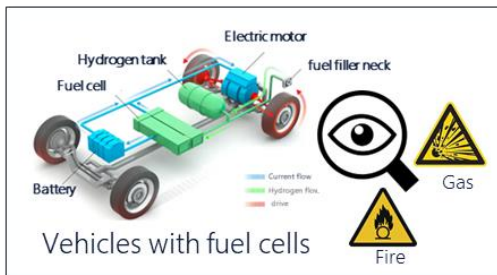

### Kinematics

- More spoiler systems for e-vehicles as key for longer range
- Integrated seat-technology for more comfort and autonomous driving, e.g. folding tables (lunch tray, rear passengers; integrated charging, display, keyboard)
- Charging doors for e-vehicles
- Actuators (e.g. for smart doors)



The Strategy

**Strategy for paragon’s ongoing Growth - Intensification of using Growth Drivers**

**Interieur**

- New technologies for a business with traditional imprinting - due to thinking outside the box (clanging-free loudspeaker, high-quality subwoofer with mini space needs, external loudspeaker with horn function, green audio, lightweight)
- Shift away from combustion engines triggers OEMs to put more emphasis into acoustics
- Transfer of technology from home hi-fi into car hi-fi (e.g. Air-Motion-Transformer)
  - No other technology can replace loudspeakers!
  - paragon’s advantage: Outstanding know-how and reputation of loudspeakers for home hi-fi (ETON brand) **ETON**
  - **Loudspeakers will be one of paragon’s TOP3 products in coming years (2026e-2029e: cumulative >EUR 200m)**
  - Search started for location in best-cost-country for production of loudspeakers (ceasing supplies from China)

**Subwoofer system**



**Illumination**



**Green Audio**



- Hybrid instruments (digital display as face of an analogue multi-use information device „Edwin“)
- More (5...8) and better microphones per car (speech control, in-car communication, noise cancellation, sound bubble)
- Wireless charging of mobile devices with higher power



Edwin



Wireless Charging

**Power**

- After selling the low-voltage battery business to Clarios, paragon remains Clarios’ supplier for **Battery Management Systems** (BMS)
- paragon with its world-class smart technologies will play a role in the global BMS-business in future
- Main growth driver is the use of the game-changing **FSD-technologies** for traction batteries of vehicles



Battery Management Systems

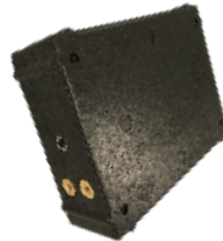

Flow Shape Design



Traction Batteries



The Strategy

**Continuation of Regional Expansion**

Regional Strategy	Comments
<p>The map illustrates Paragon's regional expansion strategy. A central grey world map features four dark blue highlighted regions: North America (USA), Europe, China, and South Korea. Curved arrows labeled 'Go East' and 'Go West' indicate expansion directions. Small icons of the US, China, India, and South Korea flags are placed near their respective regions.</p>	<ul style="list-style-type: none"> <li>  <ul style="list-style-type: none"> <li>▪ Finalization of localization of products</li> <li>▪ Increasing of internal production</li> <li>▪ Offering full paragon product portfolio</li> <li>▪ R&amp;D for special product variants for Chinese and Korean market</li> </ul> </li> <hr/> <li>  <ul style="list-style-type: none"> <li>▪ Establishing of Detroit sales office</li> <li>▪ Preparing later production location</li> </ul> </li> <hr/> <li>  <ul style="list-style-type: none"> <li>▪ Joint Venture with Indian Tier 1</li> </ul> </li> <hr/> <li>  <ul style="list-style-type: none"> <li>▪ Joint Venture with Korean Tier 1</li> </ul> </li> </ul>

Executive Summary

Since more than 35 years, paragon has built an Automotive Tier 1 with proprietary Products

paragon at a Glance

- ❑ **Well-established business model** provides a strong foundation for further growth
- ❑ paragon has **demonstrated resilience** in highly competitive markets
- ❑ After refocusing in recent years, **paragon is ready to achieve the next level** of its corporate development



paragon's Growth Strategy

- ❑ paragon's growth strategy consists of three elements:
  - 1) Usage of paragon's products in **higher-volume premium models** and by more OEMs in Europe and China
  - 2) Further **regional expansion** to USA, India and South Korea
  - 3) Development of **multi-disciplinary and industrial sector agnostic products**



## Executive Summary

Since more than 35 years, paragon has built an Automotive Tier 1 with proprietary Products

### paragon at a Glance

- ❑ **Well-established business model** provides a strong foundation for further growth
- ❑ paragon has **demonstrated resilience** in highly competitive markets
- ❑ After refocusing in recent years, **paragon is ready to achieve the next level** of its corporate development



### paragon's Growth Strategy

- ❑ paragon's growth strategy consists of three elements:
  - 1) Usage of paragon's products in **higher-volume premium models** and by more OEMs in Europe and China
  - 2) Further **regional expansion** to USA, India and South Korea
  - 3) Development of **multi-disciplinary and industrial sector agnostic products**



# Disclaimer

- \_ This presentation is given to you in strict confidence. By attending the presentation, you agree that no part of this presentation or disclaimer may be disclosed, distributed or reproduced to any third party without the consent of paragon GmbH & Co. KGaA ("paragon").
- \_ This presentation is being provided for the sole purpose of providing the recipients with background information about paragon's business. This presentation, including the information contained in this disclaimer, does not constitute an offer, invitation or recommendation to subscribe for or purchase any security and neither the presentation, disclaimer nor anything contained in them forms the basis of any contract or commitment. This presentation does not purport to summarize all information that an investor should consider when making an investment decision. It should be read in conjunction with paragon's other continuous disclosure announcements. Before making an investment decision you should consider whether it is suitable for you in light of your own investment profile and objectives and financial circumstances and the merits and risk involved.
- \_ No representation, express or implied, is made as to the fairness, accuracy, completeness or correctness of information, opinions and conclusions contained in this presentation, including the accuracy, likelihood of achievement or reasonableness of any forecasts, prospects, returns or statements in relation to future matters contained in the presentation ("forward-looking statements"). Such forward-looking statements are by their nature subject to significant uncertainties and contingencies and are based on a number of estimates and assumptions that are subject to change (and in many cases are outside the control of paragon and its Directors) which may cause the actual results or performance of paragon to be materially different from any future results or performance expressed or implied by such forward-looking statements. Forward looking statements are provided as a general guide only and should not be relied upon as an indication or guarantee of future performance.
- \_ To the maximum extent permitted by law, neither paragon nor its related corporations, directors, employees or agents, nor any other person, accepts any liability, including, without limitation, any liability arising from fault or negligence, for any loss arising from the use of this presentation or its contents or otherwise arising in connection with it.
- \_ You represent and confirm by attending and/or retaining this presentation, that you accept the above conditions.



The background of the entire page is a long-exposure photograph of a tunnel. The perspective is from the center of the tunnel, looking towards the bright exit. The walls and floor of the tunnel are blurred into streaks of light, primarily in shades of blue and purple, with some orange and yellow light trails near the exit. The sky at the end of the tunnel is a bright, clear blue.

PARAGON®

paragon GmbH & Co. KGaA  
Bösendamm 11  
33129 Delbrück  
Tel.: +49 (0) 5250 9762 - 0  
E-Mail: [info@paragon.ag](mailto:info@paragon.ag)